

CONVEYOR BELT COVERS, STEEL

Pre-formed corrugated sheets for conveyor belt housings

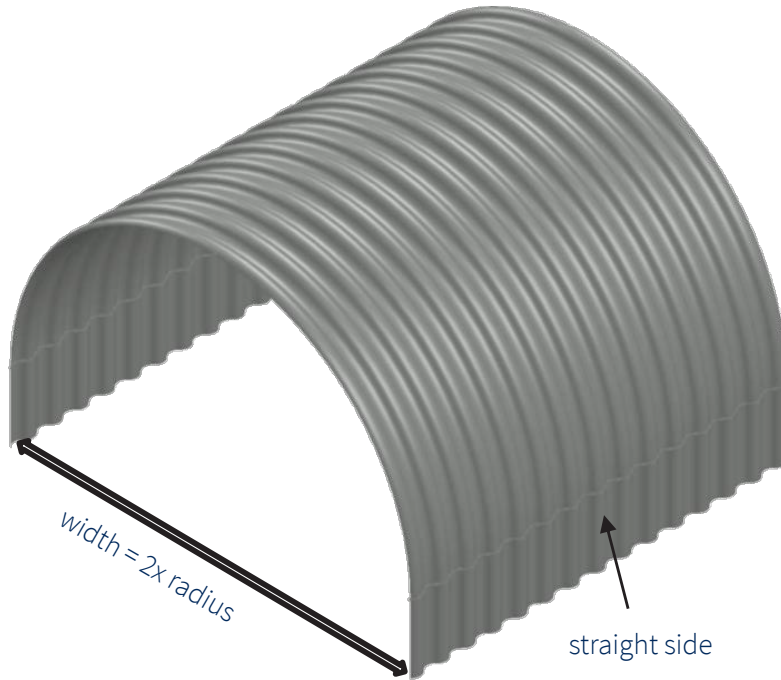

MATERIAL

T-Rex covers are pre-formed corrugated sheets manufactured with steel 76 x 18 sheets. They are made from high tensile steel, hot dip galvanized. Standard steel thickness 0,63 mm (other thicknesses upon request, available from 0,63 to 1,25 mm).

APPLICATIONS

- ✓ Protection of the conveyed materials against bad weather allows energy savings for products transformed by combustion.
- ✓ Protection of the belt conveyor from sun and/or bad weather offers greater longevity and avoids the retention of rain water.
- ✓ Finally, the protection of materials reduces the maintenance of the rolls and ensures a waterproof environment between all industrial buildings connected by the belt.

PROFILE 76 x 18

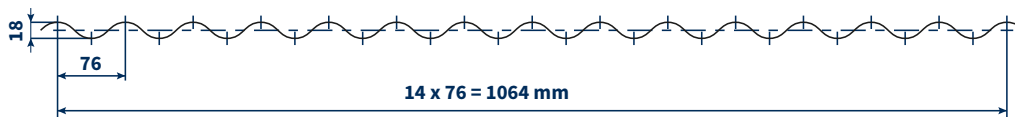

DIMENSIONS

Standard thickness 0,63 mm (other thickness upon request: 0,63 to 1,25 mm).

Cover no.	A Belt width (mm)	B Width (mm)	R Radius (mm)	C Height straight side (mm)	Weight of full cover (kg)
1	400	700	350	200	9,38
2	500	800	400	200	10,35
3	650	950	475	200	11,79
4	800	1150	575	200	13,72
5	1000	1350	675	200	15,65
6	1200	1600	800	200	18,06
7	1400	1800	900	200	19,99
8	1600	2050	1025	200	22,40
9	1800	2250	1125	200	24,33

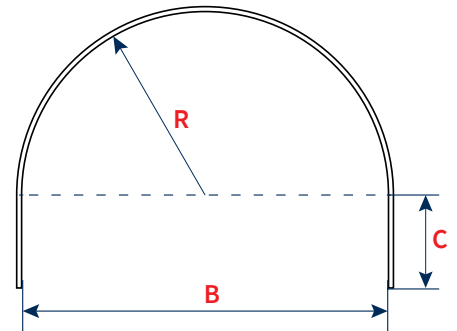

Nylon fixing straps for covers no.

Belt width (mm)

1 + 2 + 3	400 - 650
4 + 5	800 - 1000
6 + 7	1200 - 1400
8 + 9	1600 - 1800

ASSEMBLY

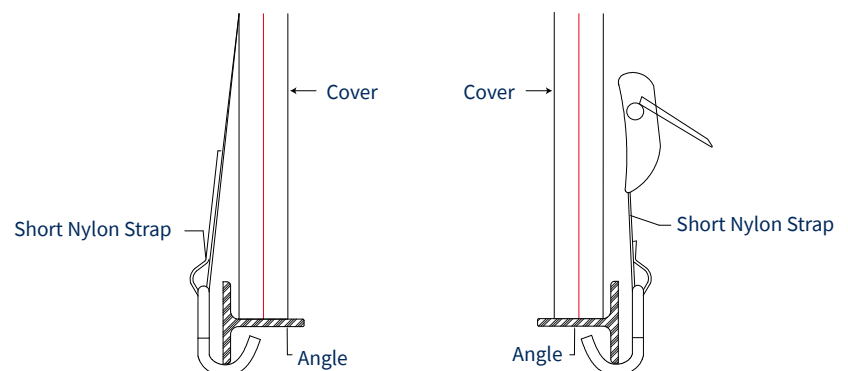
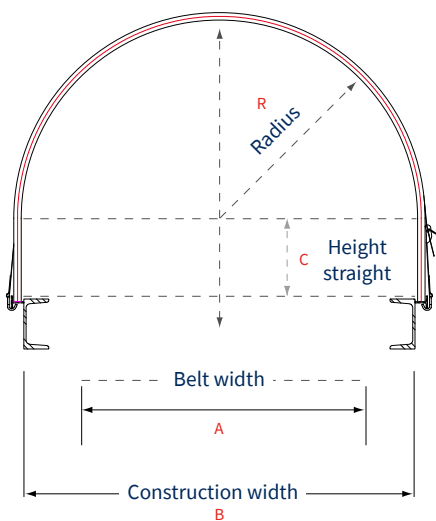

MOUNTING SCHEME

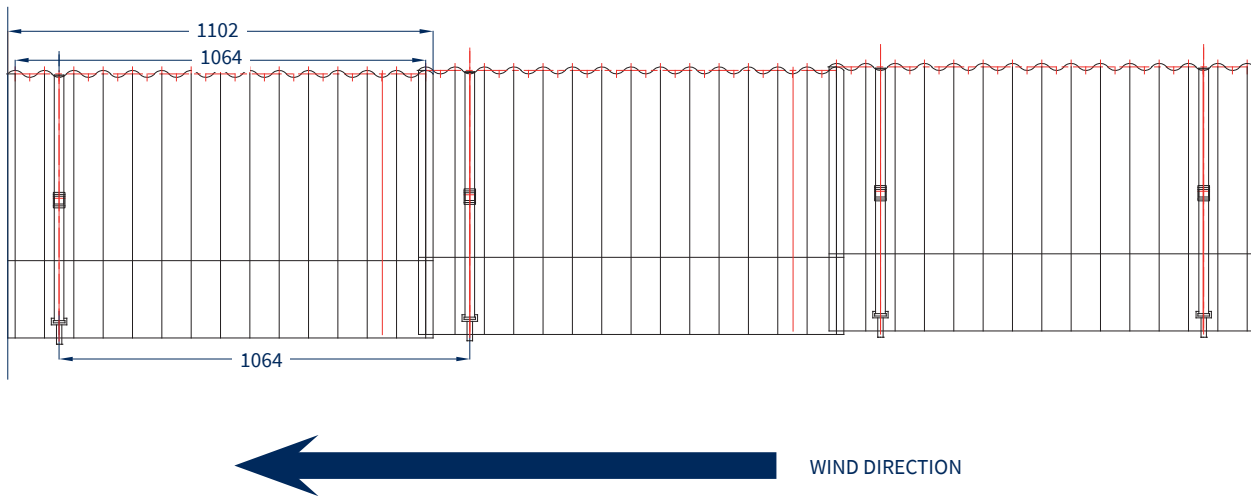

REASONS FOR CHOOSING T-REX COVERS

PROTECTING CONVEYORS AND CONVEYED MATERIALS : A GROWING NECESSITY

T-Rex covers are pre-formed corrugated sheets manufactured with steel 76 x 18 sheets. The measures adopted in favour of environmental protection and safety for personnel encourage the installation of covers. Besides these two aspects, other reasons indicate their use:

ECONOMICAL

- ✓ Lower costs compared to other systems or materials;
- ✓ Easy to install;
- ✓ Self supporting;
- ✓ Suitable for all frames;
- ✓ Maintenance free.

ROBUST

- ✓ Unbreakable, Weatherproof resistant to frost and ultra violet light);
- ✓ The coating is adapted to suit the site and the internal environment;
- ✓ Fire classification M 0.

FUNCTIONAL

- ✓ Easy to handle covers can be supplied with handles or doors;
- ✓ The perpendicular corrugation facilitates the flow of rainwater down the sides and thus provides better waterproofing at the overlaps which helps to avoid premature corrosion;
- ✓ Easy fasteners allow for rapid disassembly for quick intervention on the conveyor belt.

